

LOCOPUMP S2

Pneumatic Pump

User and Maintenance Manual

Original text translation

ITALY

Dropsa SpA
t. +39 02-250791
f.+39 02-25079767

U.K.

Dropsa (UK) Ltd
t. +44 (0)1784-431177
f. +44 (0)1784-438598

GERMANY

Dropsa GmbH
t. +49 (0)211-394-011
f. +49 (0)211-394-013

FRANCE

Dropsa Ame
t. +33 (0)1-3993-0033
f. +33 (0)1-3986-2636

CHINA

Dropsa Lubrication Systems
(Shanghai) Co. Ltd
t. +86 (021) 67740275
f. +86 (021) 67740205

U.S.A.

Dropsa Corporation
t. +1 586-566-1540
f. +1 586-566-1541

AUSTRALIA

Dropsa Australia Ltd.
t. +61 (02)-9938-6644
f. +61 (0)2-9938-6611

BRAZIL

Dropsa do Brasil Ind. e
Com. Lta
t. +55 (0)11-563-10007
f. +55 (0)11-563-19408

TABLE OF CONTENTS

1. INTRODUCTION
2. GENERAL DESCRIPTION
3. PRODUCT IDENTIFICATION
4. TECHNICAL CHARACTERISTICS
5. COMPONENTS
6. UNPACKING AND INSTALLING
7. OPERATING INSTRUCTIONS
8. TROUBLESHOOTING
9. MAINTENANCE PROCEDURE
10. DISPOSAL
11. ORDERING INFORMATION
12. DIMENSIONS
13. HANDLING AND TRANSPORTATION
14. OPERATING HAZARDS
15. PRECAUTIONS



1. INTRODUCTION

This user and maintenance manual relates to the “LOCOPUMPS2”.

The latest version may be obtained from the Technical-Commercial Office, or by consulting our web site <http://www.dropsa.com>.

This user and maintenance manual contains important information about protecting the health and safety of the personnel who intend to use this apparatus. You must read and look after it carefully, making sure that it is available at all times for the operators who intend to consult it.

2. GENERAL DESCRIPTION

The pneumatic pump “LOCOPUMP S2” uses compressed air to control the grease quantity which is delivered from the pump. Hence, it should be used on machines where compressed air is readily available.

It's a grease single effect pneumatic pump generally used in systems with single-line progressive dividers as SMX, SMO, SMP or SMPM.

In the standard version the pump is fitted of a 2kg reservoir spring loaded, whereby the pump can easily provide grease NLGI 2. The transparent reservoir allows to see clearly the amount of remaining grease moreover there is a minimum level sensor. This pump is designed to mount a maximum level sensor and an adjustable delivery kit.

Loading connection is completed of a filter guaranteeing the input of clean lubricant into the reservoir.

It's possible to use a filtered clean grease return in the reservoir.

3. IDENTIFICATION OF THE MACHINE

On the front part of the pump tank there is a plate which indicates the product code, the supply voltage and the basic characteristics.

4. TECHNICAL CHARACTERISTICS

TECHNICAL CHARACTERISTICS	
Pumping system	Single acting pneumatic piston
Air pressure	3÷6 bar
Compressed air inlet	G 1/8 UNI - ISO 228/1 with cone seating for 6mm tube
Reservoir refilling	grease nipple with check valve type UNI 7663 – “A” – 1/8” NPT
Lubricant outlet	G ¼ UNI – ISO 228/1
Reservoir return	G ¼ UNI – ISO 228/1
Compression ratio	50:1
Fixed delivery	2 cm ³ /stroke
Adjustment delivery (kit 3133390)	0.5 ÷ 2 cm ³ /stroke
Max. grease consistence	NGLI 2
Piston total stroke	36.5 mm
Piston working stroke	29.2 mm
Minimum level contact	V max.= 100 Vac I max.= 0.25° @ 30Vac P max.= 7.5 W (NO) – 3 W (NC)
Operating temperature	+5 ÷ +50°C
Storage temperature	+5 ÷ +50°C
Relative humidity max. noncondensing operating damp	90%
Sound pressure level	< 70 db (A)
Weight	4.5 Kg (2Kg) - 3.5 Kg (0,5 Kg)

5. COMPONENTS

The main part of the pump are:

The reservoir, constructed of transparent type plastic, compatible with commercially available greases.

The pump body, constructed of steel with capability of delivery upto 2 cm³ (0,12 cu.in) per stroke at a maximum pressure of 300 bar (4351 psi). There is an internal check valve mechanism for the grease output.

The level sensor, is an electric contact that indicates that the pump has reached its low level of grease. It's possible to set it to either "Normally Closed" or "Normally Open" (see drawing for further instruction). As standard is set to "Normally Closed".

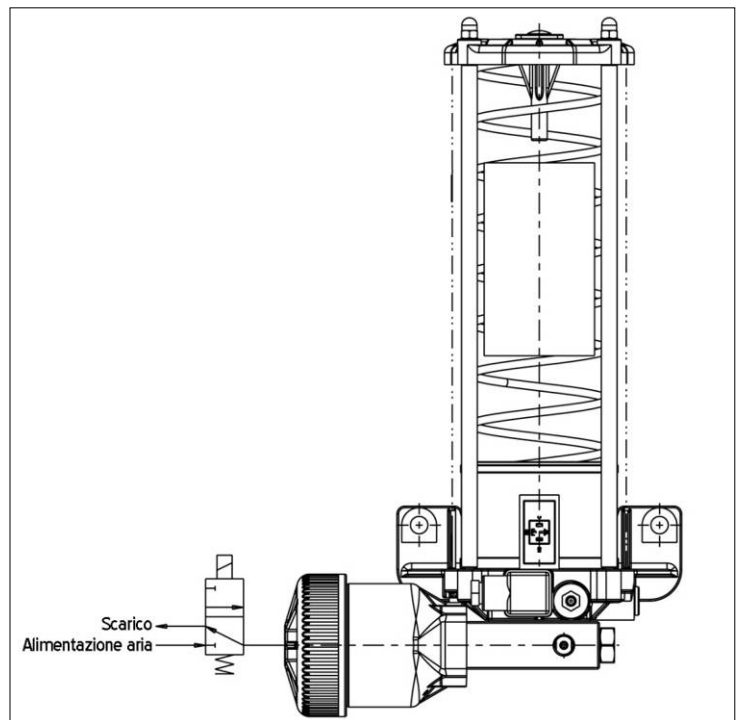
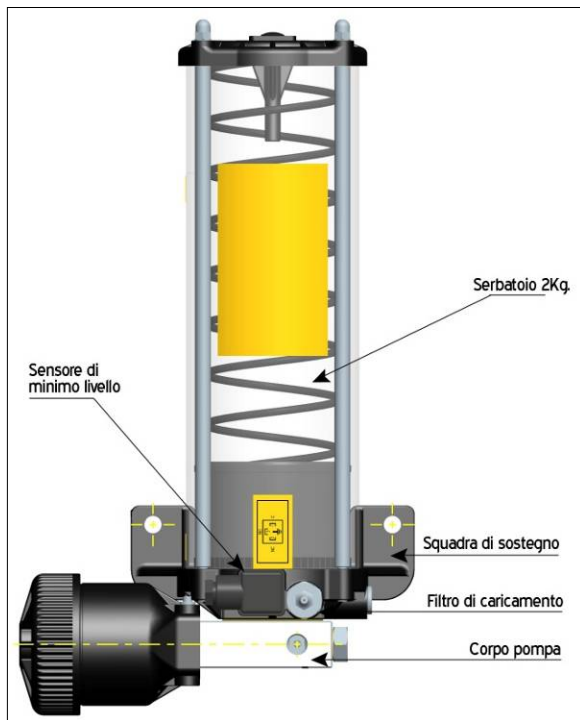

PART NUMBER	DESCRIPTION
3044260	2 Kg. (4,4 lb) Reservoir
3044515	0.5 Kg. (1,1 lb) Reservoir
3045202	Support Bracket
3413502	Body pump
1655183	Minimum level sensor
712100	Refilling Filter

5.1 PNEUMATIC GREASE PUMP WITH STANDARDIZED 400CC LUBRICANT CARTRIDGE LOADING SYSTEM

The Pneumatic Pump with cartridge grease loading is a pump for general use in single line progressive divider lubrication systems such as SMX, SMO, SMP or SMPM.

The pump is designed for all those applications where it is ideal to have grease supplied in readily available cartridges.

The pump is equipped with a steel plate with a M57x1.5 mm thread that allows interfacing with up to two 400cc lubricant cartridges.

High Reliability is guaranteed by the use of hardened steel in the construction in all the pumping element components and the pump piston is manufactured in ground hardened steel.



5.1.1 DIMENSIONS

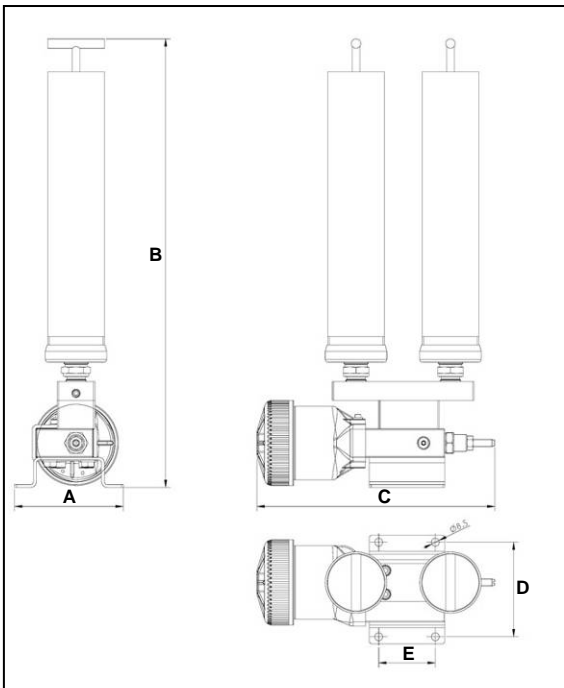

OVERALL DIMENSIONS			QUOTE OF FASTENING	
A	B	C	D	E
115	~480	252	100	60

5.1.2 ORDER INFORMATION

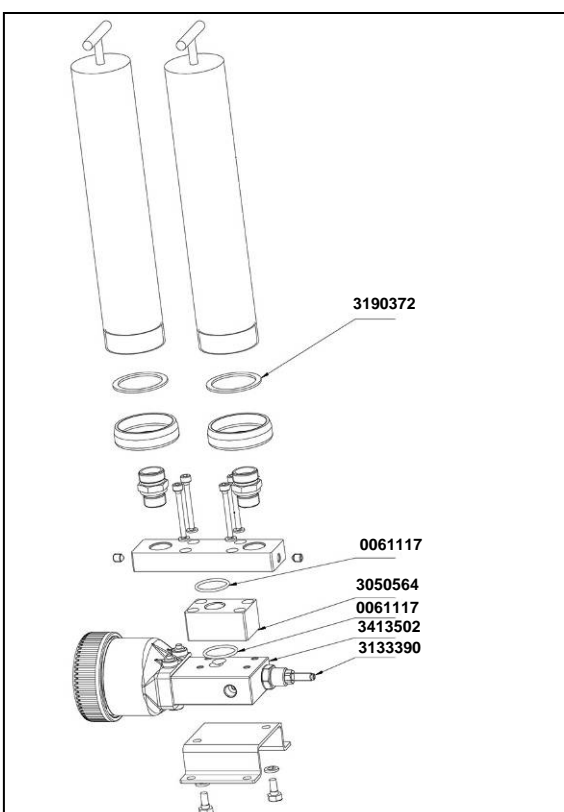

PART NUMBER	DESCRIPTION
3414064	Pneumatic pump with cartridge loading
SPARES	
3190372	Seal gasket
0061117	Gasket
3050564	Flange connection
3413500	Pneumatic pump grease R= 50:1
3133390	Pump delivery adjustment kit

6. UNPACKING AND INSTALLATION



WARNING: The unit is only to be opened and repaired by specialist personnel.

6.1 UNPACKING

Once a suitable installation position has been identified, unpack the pump and prepare for installation. It is important to inspect the pump to ensure that there has been no damage during transportation. The packaging material used does not require any special disposal procedures. You should refer to your regional requirements.

6.2 PUMP INSTALLATION

Allow sufficient space for install with 150mm clear space around the perimeter of the pump.

Mount the pump LocopumpSerie2 at “eye level” to avoid any risk of postural problems.

Do not install the pump in dangerous environments such as explosive/flammable areas or in areas subject to high vibration.

Only use the fixing holes on the support bracket which are intended for n°2 holes for screws $\varnothing 10$ mm (0,4 in.)(use a flat washer with the screw). For more details of the fixing holes please verify the dimensions shown on the drawing in chapter 12.

6.3 ELECTRICAL CONNECTIONS

Ensure the electrical connection of the low level is connected before using the pump. See below drawing for connection details. A label of this drawing is also on the pump’s reservoir.

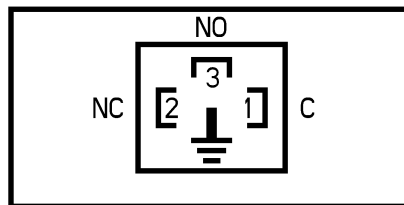

Supply voltage 24 V max.

6.4 PUMP OUTLET CONNECTION

The hydraulic connection of the pump is on the front face of the pump. It is a standard 1/4” BSP (see drawing in chapter 12).

6.5 AIR CONNECTION ON PUMP

Use an 1/8” BSP connection fitting. It is also possible to use DropsA’s nut and cone fittings as the seating is already available.

Remember to use a 3/2 valve that allows the air to vent to atmosphere and the internal spring within the pump to reset.

6.6 HOW TO ADJUST THE PUMP OUTPUT OR PRESSURE

This can be done by :Regulating pressure: the output pressure has a 50:1 ratio with the inlet pressure. Therefore this can be regulated depending on the requirements of the system. (see chapter 4 for min and max pressures).

Regulating pump: as standard the pump has a fixed output. For special requirements you can convert the pump by installing the kit 3133390 – *ordered separately to the pump* – the kit is shown below.

To use this kit , mount the o-ring (A) then tighten the fitting (B) with a 27mm spanner. Loosen the counter nut (C) with a 13 mm spanner to unblock the screw (D), use the appropriate screw driver to screw IN for less output or screw OUT for more output. After adjustments have been made you must tighten the counter nut (C) to block any further movements.

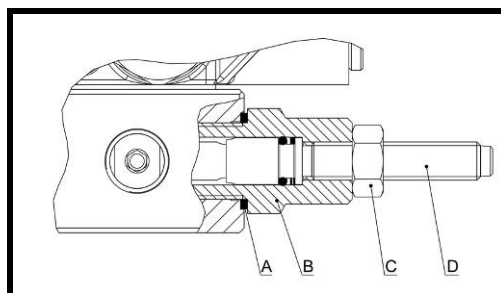

N.B.: After all connections have been made please ensure that they are safe and properly secured down.

7. INSTRUCTIONS FOR USE

7.1 Start Up

- The unit should only be used, opened and repaired by specialized personnel only.
- It is prohibited to use the pump if it is submersed in fluid, in dangerous environments or explosive/flammable areas unless pre-agreed with supplier and appropriate safety/protection measures have been put in place.
- Use gloves and safety glasses as advised in the grease lubricant safety data sheet.
- DO NOT use aggressive lubricants on the NBR seals, if in doubt consult DropsA Spa technical office who can offer advice on lubricants and provide a pre-approved list of greases.
- Ensure proper precaution to keep the pump clean and avoid and potential health hazards.
- Always use suitably pressure rated tubing for the lubrication system.

7.2 Action to be taken before start-up.

- Check the integrity of the pump.
- Refill the tank with suitable lubricant.
- Check that the pump is at working temperature and that there are no air bubbles in the pipes.
- Check that the electric connection has been carried out correctly (CEI 64/8, IEC 364).
- Ensure that the pump is properly connected to the control panel.

7.3 Use

- Check the data sets imposed.
- Press the start button on the machine to which the Sumo pump is connected.
- Check pump start-up.
- Check that the machine is adequately lubricated (if there are still some doubts about its correct functioning you can contact the Dropsa S.p.A Technical Office and request a test procedure).

8. PROBLEMS AND SOLUTIONS

Below is a diagnostic table showing the main faults, the probable causes and the possible solutions.

In the event of doubts and/or problems which cannot be solved, do not proceed to look for the fault by dismantling parts of the machine, but contact the Dropsa Technical Office.

DIAGNOSTIC TABLE		
FAULT	CAUSE	SOLUTION
The pump does not deliver grease or does not deliver the correct amount of grease	The grease level is below minimum.	Add more grease into the reservoir without surpassing the MAX level.
	The solenoid valve on the inlet of the pump does not vent.	Verify it the solenoid vents. Vent the solenoid manually and monitor if the grease flows out.
The pump does achieve required pressure or does not maintain its operating pressure.	The fittings are leaving/loose.	Tighten the fittings and check for leaks on all fittings.
	Regulation of air inlet pressure..	Adjust the air pressure on the inlet of the pump taking into account the pressure ratio.
	Internal Check valve is damaged or contaminated.	Clean or change the valve shown in kit 3133391.

9. MAINTENANCE PROCEDURES

Ensure the pump is positing so that it can be verified easily.

Ensure you have necessary personal protective equipment to avoid any contact with the grease.

The pump undergoes severe factory testing therefore no maintenance is forecasted with the pump.

DropsA recommends the use of lubricants that are free of any impurities as well as a regular cleaning of the pump's components.

The pump is dismantled as follows :

1. **Before removing the reservoir is must be completely emptied of lubricant.**
2. Disconnect the air inlet connection.
3. Disconnect all tubing on the pump.
4. Loosen the screws on the lid, remove the reservoir **taking ABSOLUTE care of the spring inside the reservoir (it may still be under tension – if so remove more lubricant.)**
5. Remove the pump and any filters if fitted.
6. Unscrew the plug on the pneumatic pump body , **be careful** of the load on the internal spring. At this point you can remove the internal components of the pump body.

At this point all components are loose and allows the cleaning and verifying of each component possible.

All components must be clean with cleaning fluid and lubricated before re-assembly.

Periodically it is necessary to check:

CHECK	TOTAL NUMBER OF PUMP CYCLES
The lubrication status	100
Lubricant level	200
Clean refilling filter	400
Clean bottom of reservoir if deposits have formed.	600

The machine does not require any special equipment for any checking and/or maintenance activity, however the recommendation is to use suitable equipment which is in a good condition (according to current regulation) in order to avoid causing damage to persons or machine parts.

Make sure that the electric and hydraulic supply has been disconnected before carrying out any maintenance intervention.

10. DISPOSAL

In the course of machine maintenance, or if the machine is scrapped, do not dispose of polluting parts into the environment. Refer to local regulations with regard to their correct disposal. When scrapping the machine the identification plate and any other documents must be destroyed.

11. INFORMATION ABOUT ORDERING

PART NUMBER	FEATURES
3413050	Pneumatic pump R=50:1 Reservoir 2 Kg (4,4 lb)
3133391	Seal kit spares
3133390	Adjustable pump output kit
3133392	Kit max level
3413050 C	Preloaded pneumatic pump R=50:1 Reservoir 2 Kg (4,4 lb)

12. DIMENSIONS

To facilitate future maintenance, increase the spaces indicated by at least 100 mm.

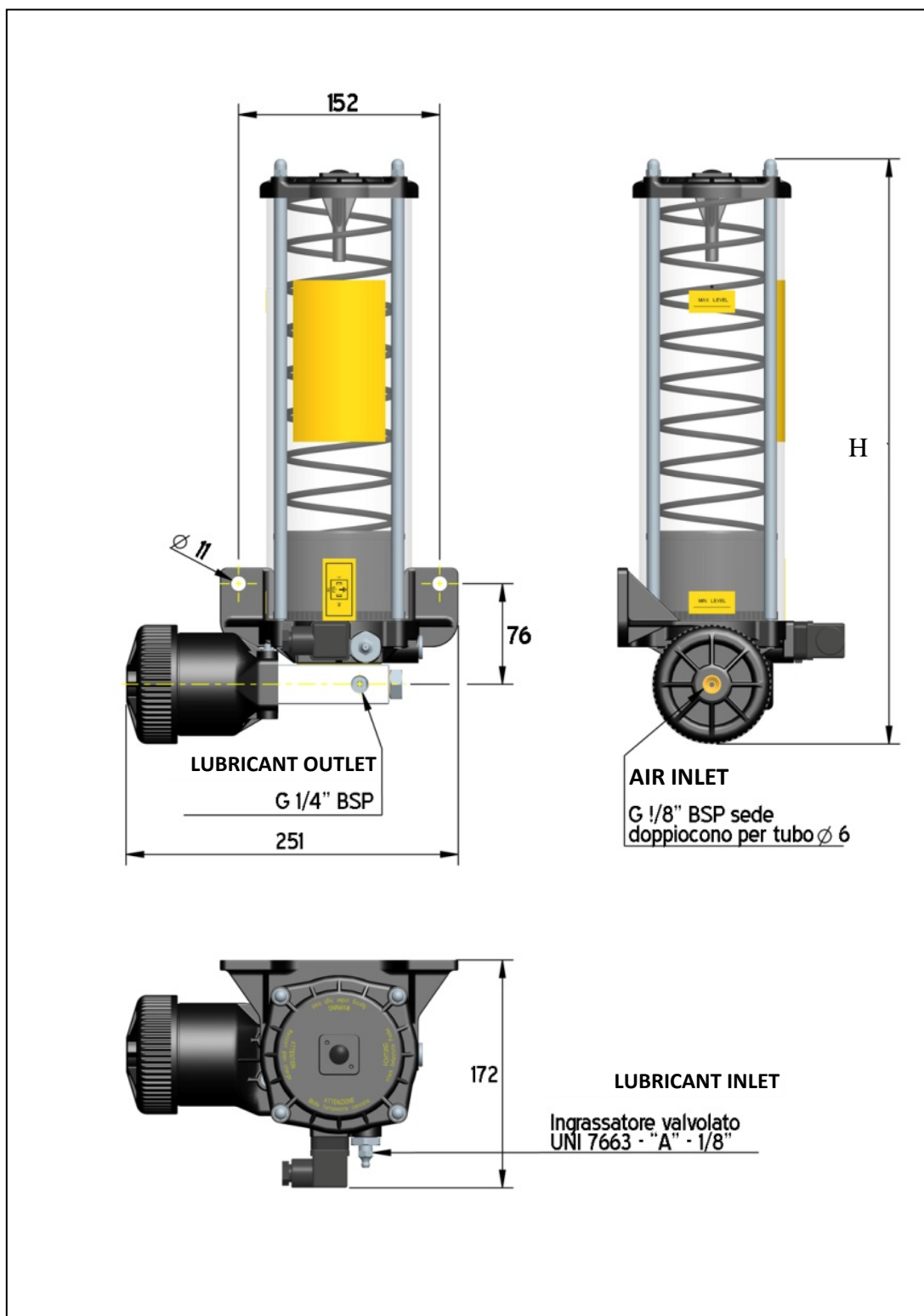

	2 Kg	0.5 Kg
H	441.6	253

13. HANDLING AND TRANSPORT

Prior to shipping, the equipment is carefully packed in cardboard package. During transportation and storage, always maintain the pump the right way up as indicated on the box. On receipt check that package has not been damaged. Then, store the machine in a dry location.

14. PRECAUTIONS FOR USE

It is necessary to carefully read the warnings and risks associated with using a lubricant pump. The operator must understand how it works and must clearly understand the dangers by studying the user manual.

Power supply

Any type of intervention must not be carried out before unplugging the machine from power supply. Make sure that no one can start it up again during the intervention.

All the installed electric and electronic equipment, reservoirs and basic components must be grounded.

Flammability

The lubricant generally used in lubrication systems is not flammable. However, it is advised to avoid contact with extremely hot substances or naked flames.

Pressure

Prior to any intervention, check the absence of residual pressure in any branch of the lubricant circuit as it may cause oil sprays when disassembling components or fittings.

Noise

Pump produces noise, not more than 70 dB(A).

15. OPERATIONAL HAZARDS

The check on compliance with the essential safety requirements and with the stipulations indicated in the machine directives are to be carried out by means of compiling the checklists already made available and contained in the *technical file*.

Two types of lists were used:

- List of dangers (section from UNI EN ISO 14121-1 relating to UNI EN ISO 12100)
- Application of the essential safety requirements (Machine Dir.)

See below a list of dangers which have not been completely eliminated, but are considered acceptable:

- During assembly/maintenance it is possible that there may be an oil splash (consequently this operation must be carried out using appropriate individual protective devices);
- contact with oil -> see instructions for using appropriate individual protective devices DPI;
- **Loaded springs**, in the pump cylinder and in the reservoir.
- Use of an inappropriate lubricant -> fluid characteristics indicated both on the pump and in the manual (**if in doubt consult our Technical Office**);
- protection against direct and indirect contact must be provided by the user;
- The pump's working logic requires it to operate at all times, so it is necessary to pay attention to the electric connection. If there is no current the customer's machine can only be restarted following a reset while the lubrication pump can restart automatically.
- Do not use alcohol or spirits to clean any components.

UNACCEPTABLE FLUIDS	
Fluids	Dangers
Lubricant with abrasive additives	High consumption of contaminated parts
Lubricant with silicon additives	Jamming of the pump
Benzine – solvents – inflammable liquids	Fire – explosion – damage to gaskets
Corrosive products	Corrosion of the pump – injuries to persons
Water	Pump oxidation
Food substances	Contamination of these substances